

OERLIKON

LAPPING MACHINE

BEVEL GEAR TECHNOLOGY – LAPPING MACHINES



KLINGELBERG

A LEADER IN BEVEL GEAR TECHNOLOGY

Intelligent Solutions for Discerning Users

All around the world, manufacturers of gearwheels and gearboxes ensure their leading edge in gear machining with innovative solution concepts from Klingelberg.

The **Oerlikon Bevel Gear Technology** division makes economical, high-precision production of bevel gears a reality for users. All machines have been perfectly designed to work as a system family, enabling pre-machining and finishing of even the most complex gears.

Klingelberg offers the most advanced technology and the most efficient machines for each and every step in the process chain. The production process chain for bevel gears includes **tool preparation, cutting, measuring**, hardening, **grinding or lapping** and **testing**, among others. The powerful **KIMoS (Klingelberg Integrated Manufacturing of Spiral Bevel Gears)** design software and the **Closed Loop concept** ensure transparency and documented quality through the entire process chain.

Oerlikon bevel gear machines were developed with real-world applications in mind and meet the varying demands of a whole range of application industries. The target markets include the automotive industry, the commercial vehicle industry, the agricultural industry, shipbuilding, and aviation, as well as industrial gear unit manufacturing and plant engineering.

Klingelberg, as a leading system supplier, also offers high-performance tools, and with this complete system, meets every requirement for flexible, efficient production – for the smallest and the largest lot sizes.



OERLIKON L 60 bevel gear lapping machine

Exceptional Concepts for Every Process Step in Gear Technology

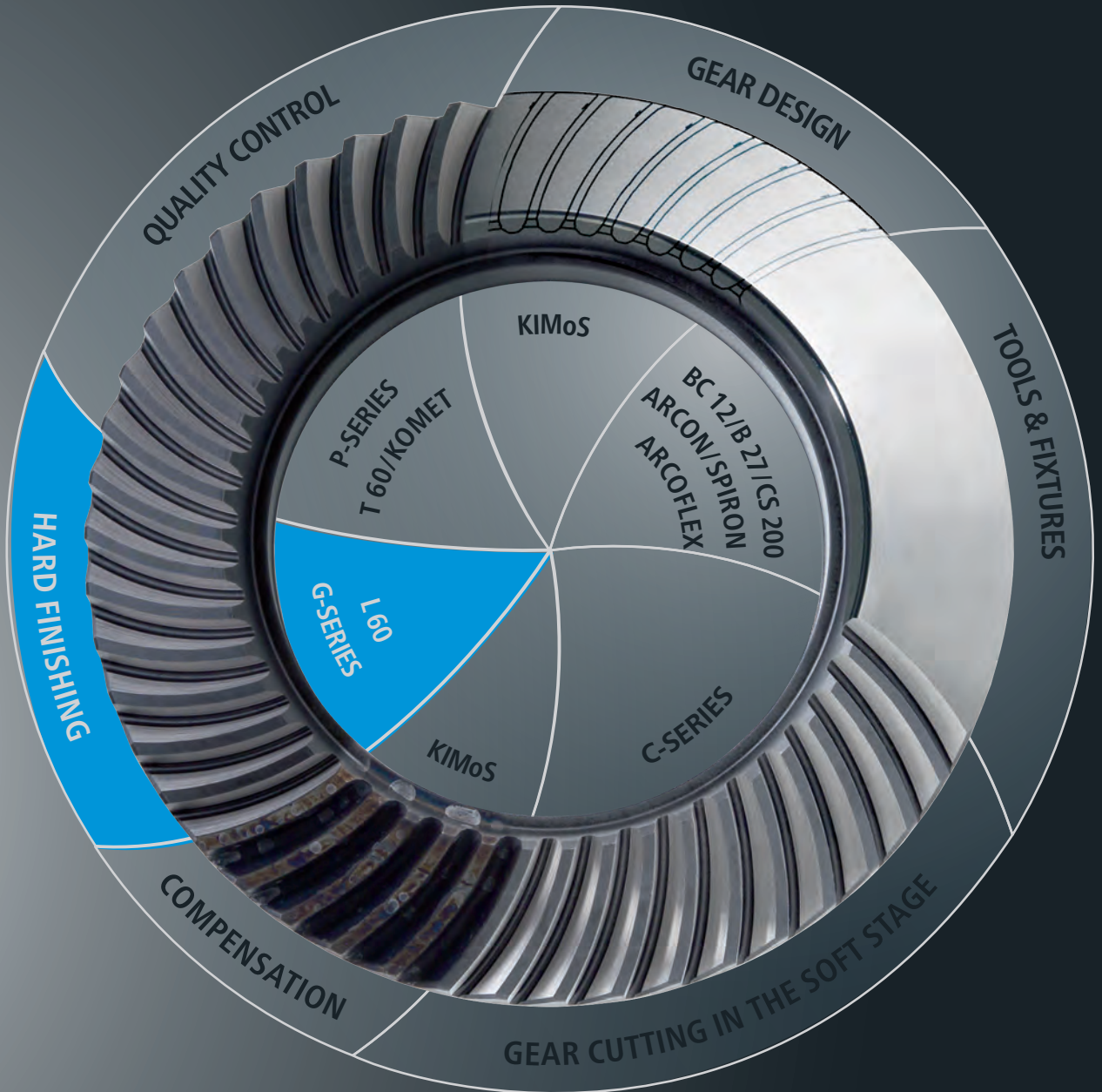

HIGHLIGHTS

Lapping: the high-productivity method for noise-sensitive applications

- Minimized cycle time for hard finishing by simultaneously processing the pinion and ring gear in one production step
- Flexible contact pattern presentation, since lapping is not tied to the machine kinematics of a conventional bevel gear machine
- No significant occurrence of higher tooth-mesh orders
- Optimal psycho-acoustic noise behavior in the partial-load and full-load range

The lapping process is particularly employed in industrial scale manufacturing, where noise-critical behavior is a key factor.

Highly Efficient Lapping of Spiral Bevel and Hypoid Bevel Gear Sets

Oerlikon bevel gear lapping machines are designed to allow all operational tasks, as well as loading and unloading, to be carried out from the front of the machine. The result is a completely new configuration of machines on the factory floor.

The intelligent machine design allows for a minimized, active space requirement. The passive floor space has also been designed to enable a tighter layout of individual machines on the factory floor. As a result, non-productive areas and walkways for the operating staff can be considerably reduced.



OERLIKON L 60 bevel gear lapping machine

The L 60 CNC bevel gear lapping machine has three linear axes for fully automatic lapping of spiral bevel and hypoid gear sets with a 90° shaft angle. Shaft angles from 79° to 101° are optionally available. The L 60 offers an efficient lapping technology with versatile, intuitive customization options for optimal process design.



User-friendly Machine Design

- All operational tasks—such as loading, unloading, and retooling—can be performed from the front
- Wide-opening working chamber doors provide easy accessibility for retooling and manual loading
- Intuitive user software prevents improper operation
- Optional foot switch to clamp and release workpieces



Efficient and Reliable Production

- Extremely small space requirement thanks to compact machine design and access options designed for easy operation and maintenance
- Efficient clamping device change using quick-release system
- Suitable for automatic loading
- Lapping of both hands of spiral with counter-rotating axis offset of a parts family without reconfiguring the machine. This is possible due to the up to four individually adjustable lapping compound nozzles (optional)
- Lapping compound flow control ensures constant conditions (optional)

Erweiterte Klopfererkennung			
120	Ritzeldrehzahl	4	Anz. T-Radumdreh.
80	Schwellw. Ritzel [%]	2.5	Verhältnis Ritzel
70	Schwellw. T-Rad [%]	3.0	Verhältnis T-Rad
80	Schwellw. gesamt [%]	4.0	Verhältnis gesamt
0.000	Absol. Tol. Ritzel [mm]	80	Toleranz Ritzel [%]
0.000	Absol. Tol. T-Rad [mm]	80	Toleranz T-Rad [%]
0.000	Absol. Toleranz [mm]	80	Toleranz gesamt [%]
0	0	1.6	

Maximum Quality Control Before Lapping

- Automatic detection of tooth flank damage in the active meshing range with simultaneous detection of damage counts on the pinion and ring gear
- Double-flank test allows detection of improperly clamped parts or components with out-of-tolerance concentricity errors even before lapping begins
- Can also be used as a roll tester



State-of-the-art Lapping Technology for Spiral and Hypoid Bevel Gears

- Exceptional machine functionality due to tried-and-tested horizontal spindle concept with innovative compound slide and axis concept
- System design ensures stable lapping rotation speed of the gear set during the lapping process
- Comprehensive, flexible technology optimizing options for the lapping process, beyond the standard lapping cycle
- LAC technology for easy manipulation of the contact pattern without changing the lapping duration
- Reduced-load acceleration to lapping rotation speed (optional)

HIGHLIGHTS



Intelligent Automation Concepts for Maximum Productivity

- Interface provided for handling systems (robot loading or gantry loading) and automatic loading and unloading of the lapping machine enables maximum productivity and production feasibility
- Integration in fully automated production lines for optimal workflow
- Machine fixing elements for precise positioning and mechanical attachment of the machine



Maximum Process Stability with Cone Gauges

- A cone gauge designed specifically for a gear set or gear set family allows differences between the absolute coordinate system and the target mounting position to be identified and corrected
- Undesired variations between several machines that produce the same gear set can be avoided



Numerous Add-on Options for the Lapping Machine

- Light curtain for monitoring the front working chamber door to enable faster startup of the lapping cycle
- A axis including software for 79° to 101° shaft angles, so even bevel gear sets with a 90° shaft angle deviation can be lapped
- Lapping compound flow control for measuring, controlling and monitoring the lapping compound flow rate and setting the setpoint selection in the HMI.
- Integrated lapping compound vapor extraction unit

Professional Production Based on Intelligent Concepts



Intuitive Operating Concept

- Input of key process parameters with user-friendly, sturdy "one touch" keys
- Versatile technology options such as feed variation, Lap-Around-Center (LAC) and backlash compensation for optimal process design

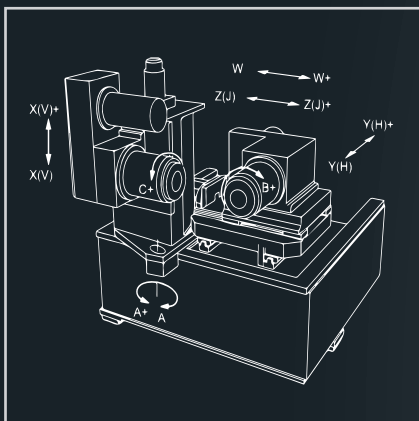

Stable Drive Concept

- Minimal space requirements and easy accessibility for operation and maintenance along with high dynamic stability due to an optimized axis concept and compact machine design
- Extreme rigidity with thermal stability provided by temperature compensation for optimal machining results, even for high-productivity processes



Maintenance-friendly Machine Design

- Lapping compound refreshing and replacement from the front of the machine
- An existing lapping compound central supply system can be connected
- Efficient maintenance thanks to easy accessibility
- No hydraulics
- Easy-to-read pneumatics layout on a central maintenance unit

Drive Components with Guaranteed Quality Provide Optimal Performance

In countless industries, Klingelberg solutions have become a staple on the international market. To meet market requirements for high productivity in mass production and ensure flexibility in small-batch production, Klingelberg offers a range of solution concepts for just about any requirement.

Used throughout the world, the [Simplified with Passion](#) system plays an important part in ensuring that machine tasks are made simple. Moreover, the Klingelberg system contributes to standardization and quality assurance on a global scale.



Automotive



In cars, spiral bevel gears are used in all-wheel-drive systems and rear-wheel-drive systems to transmit torque from the transmission "to the road". Due to increasing performance requirements, these drives must transmit outputs of over 300 kW in some cases. The bevel gears they use must be efficient, smooth-running, and low-maintenance. Reproducible quality in series production with the fastest possible production times are key requirements in this industry.

Motorcycles



Motorcycle power must be effectively delivered to the road in every situation. This is achieved by transmitting power via a bevel gear set in the drive concept, which is highly efficient in addition to being extremely durable. As a result of its long-standing experience, Klingelberg guarantees the highest product quality in bevel gear production.

Lightweight Commercial Vehicles



Rear-axle differentials are frequently used for light-weight commercial vehicles. The bevel gear sets they use must transmit power exceeding 150 kW in some cases – at extremely high torques. This places high demands on durability and strength. The bevel gear sets must be efficient, robust and low-maintenance. Use of the integrated Klingelberg system makes it possible to mass-produce bevel gears with the quality required.

Commercial Vehicles



Commercial vehicles are always rear-wheel-driven. The bevel gear sets they use must transmit power ranging up to 550 kW – at extremely high torques. This places high demands on durability and strength. The bevel gear sets must be efficient, robust and low-maintenance. Use of the integrated Klingelberg system makes it possible to mass-produce bevel gears with the quality required.

Agriculture



In agricultural applications such as tractors, spiral bevel gears are built into the rear axles, as well as the front axles in certain cases. Harvesters and hay machines use straight bevel gears to enable the corresponding functions. Whereas the bevel gear set in a tractor rear axle drive must transmit up to 400 kW, the loads on straight bevel gears are comparably low. The most important market requirement for straight bevel gears is a modern, cost-efficient production solution.

Industrial Gear Units



The industrial gear unit sector comprises many different applications, all of which place great demands on the reliability of the drive components. The bevel gears for these sectors are often manufactured by companies that are specialized in small batch sizes and a wide variety of components. A rigid machine design as well as flexible and cost-effective tool systems are the key to success in order to be a market leader here.

TECHNICAL DATA

RANGE OF APPLICATION	L 60 standard	L 60 option
Workpiece diameter (max.)	Ø 500 mm	Ø 600 mm (only with standard 90°)
Y (H) axis distance: ring gear spindle front to pinion spindle	150 – 350 mm	200 – 400 mm
Z (J) axis distance: pinion spindle front to ring gear spindle	120 – 340 mm	
Hypoid adjustment in X (V) axis	± 70 mm	
Shaft angle	90°	79° – 101°
Amplitudes of the lapping motions (max.)	± 2.5 mm	
Lapping moment (max.)	30 Nm	
Pinion headstock		
Speed range, infinitely	0 – 3,000 rpm	
Inner taper	Taper #39	Taper #50
Reduction sleeve		Taper #50 to #39
Pull-in force for workpiece clamping device (max.)	23,000 N	
Ring gear headstock		
Speed range, infinitely	0 – 2,600 rpm	
Inner taper	Taper #39	-
Reduction sleeve	-	Taper #39 to #14
Pull-in force for workpiece clamping device (max.)	23,000 N	
Network connection		
Voltage	3 x 400 V / 50 Hz (others on request)	
Tolerance of the voltage	± 10%	
Frequency/Frequency accuracy	50 Hz (others on request)/±2%	
Fuse	43 A slow-blow	
Voltage interruption	max. 10 ms	
Voltage dip	max. 15% for max. 0.5 ms	
Voltage peak	max. 200% during 1 ms	
Apparent power	23 kVA	
Harmonic content	max. 7%	
Mains symmetry	voltage difference between 2 phases max. 2% of the nominal voltage	
Network configuration	TNC	
Machine dimensions (L x W x H) approx.	2,350 x 2,240 x 2,100 mm	

The above-mentioned maximum values were determined for industry-typical transmissions. Further testing may be required to determine whether maximum values can be combined.

Installation Dimensions

L 60: FRONT VIEW

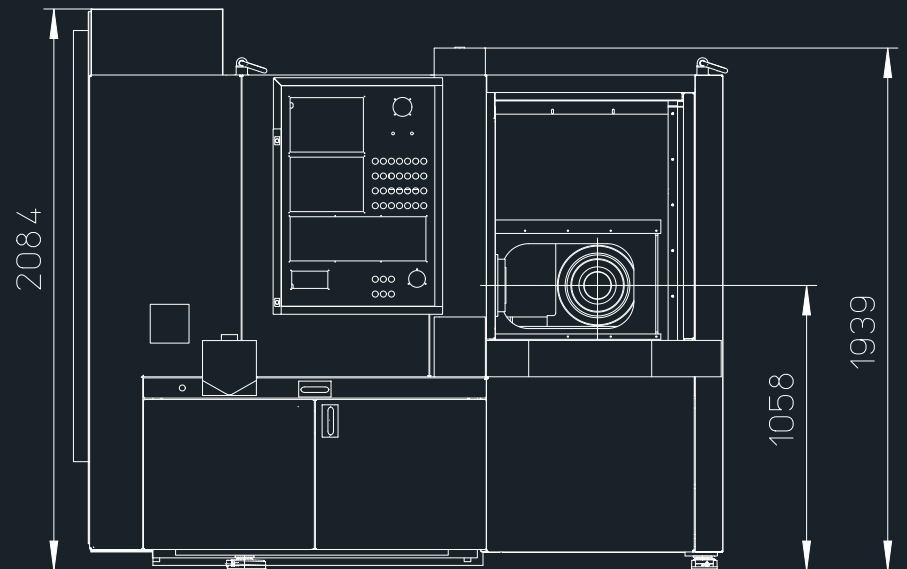

L 60: TOP VIEW

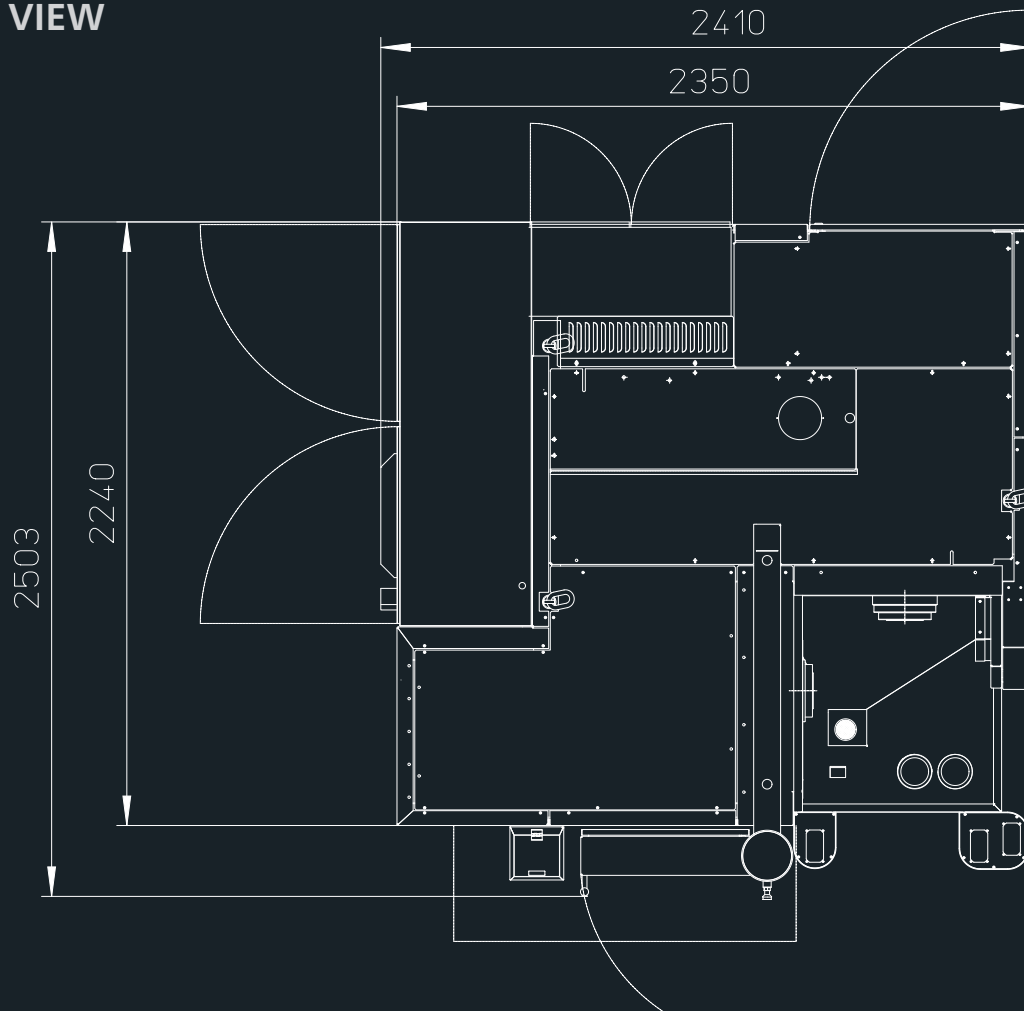

All specifications in mm

KLINGELNBERG Service

The KLINGELNBERG Group is a world leader in the development and manufacture of machines for bevel gear and cylindrical gear production, and precision measuring centers for gearing and axially symmetrical components, as well as the production of customized high-precision drive components. In addition to the headquarters in Zurich, Switzerland, further development and production facilities are located in Hückeswagen and Ettlingen, Germany.

The company also maintains a presence with Sales and Service offices and numerous marketing agents. On this basis, Klingelberg offers users a comprehensive range of services for all aspects of toothed gear design, manufacturing, and quality inspection. The spectrum includes technical consulting, on-site machine acceptance, operator and software training as well as maintenance contracts.

KLINGELNBERG Solutions

Klingelberg solutions are used in the automotive, commercial vehicle, and aviation industries, as well as in shipbuilding, the wind power industry, and the general transmission manufacturing industry. With numerous R&D engineers around the globe and over 200 registered patents, the company consistently demonstrates its capacity for innovation.

EN 12/2020 - Subject to technical modifications without notice.

FOLLOW US AND STAY UP TO DATE:



KLINGELNBERG AG

Binzmühlestrasse 171
8050 Zürich, Switzerland
Fon: +41 44 278 7979
Fax: +41 44 273 1594

KLINGELNBERG GmbH

Peterstraße 45
42499 Hückeswagen, Germany
Fon: +49 2192 81-0
Fax: +49 2192 81-200

KLINGELNBERG GmbH

Industriestraße 5-9
76275 Ettlingen, Germany
Fon: +49 7243 599-0
Fax: +49 7243 599-165

You can also find your local contact for sales advice at www.klingelberg.com/kontakt